



Mowing Your Lawn and "Grasscycling"

ALI HARIVANDI, Environmental Horticulture Advisor, UC Cooperative Extension, Alameda, Contra Costa, and Santa Clara Counties; and **VICTOR A. GIBEAULT**, Environmental Horticulturist, UC Riverside.

UNIVERSITY OF CALIFORNIA

Division of Agriculture and Natural Resources

<http://danrcs.ucdavis.edu>

This publication replaces ANR Leaflet 2587, *Mowing Your Lawn*.

An attractive lawn depends on proper mowing, in addition to other cultural practices such as irrigation and fertilization, to look its best. Mowing at a height and frequency that complement the growth habit of the grass results in a uniform, dense turf that discourages weeds and supports the turf area's intended use. Mowing too low weakens grass, causing sod to thin out, encouraging weed invasion, making the lawn more susceptible to pests, and possibly over time killing the lawn. Mowing too high produces a ragged, unattractive lawn and encourages the buildup of thatch, a spongy layer of plant debris. Mowing frequency is as important as mowing height in maintaining a healthy lawn and should be determined by the growth rate of the grass, which in turn depends on climatic conditions and the lawn maintenance program.

HOW HIGH TO MOW?

Optimum cutting height is determined by the growth habit of a particular grass and its leaf texture (i.e., the length and width of leaves). A grass's survival depends on its producing adequate leaf surface for food production through photosynthesis. Mowing too low removes too much of the grass's food producing area. As the grass literally starves, the lawn thins and looks poor. Conversely, mowing too high can hurt the appearance or usefulness of the turfed area.

No single mowing height is best for all turfgrasses; mowers must be set differently for each grass. Table 1 shows the ranges for optimum mowing heights for California lawns. Within its optimum mowing height range, each grass species will be healthier and have a deeper root system the higher the grass is mowed. Also, within its recommended mowing range, a grass that is cut higher is more tolerant of drought, heat, traffic, shade, disease, and pests than one that is cut lower.

WHEN TO MOW?

You can determine when and how often to mow your lawn by taking into account the growth rate of the grass during each season and the lawn appearance desired. Cool-season grasses will require more frequent mowing in the spring and autumn since these grasses grow most during this period. Warm-season grasses require more frequent mowing during summer months. Mow formal, ornamental areas more frequently than informal-use areas.

As a general guide, follow the *one-third rule*: mow often enough so that no more than one-third of the length of the grass blades is removed at any one time. For example, if you maintain a turf-type tall fescue lawn at 2 inches, mow it when the grass height reaches 3 inches. This may mean mowing tall fescue once a week during the spring and every two weeks during the summer. Table 1 also gives the height at which you need to mow your lawn in order to best maintain your desired lawn

height. A lower-mowed lawn will require more frequent mowing than that same lawn would if mowed higher.

WHAT TO DO WITH THE CLIPPINGS?

Grass clippings make up a surprisingly large portion of California’s solid waste stream during the growing season. With few exceptions, it is actually best to leave the clippings on the lawn after mowing. This practice, termed “grasscycling,” is growing in popularity as California communities try to reduce the amount of waste going to landfills. Grass clippings decompose quickly and release valuable nutrients back into the soil.

Grasscycling can be practiced on any healthy lawn as long as the turf is properly managed. Unfortunately, many people treat a lawn as if it were a crop: overwatering and overfertilizing it to encourage maximum growth, and then “harvesting the crop” by bagging the grass clippings and transporting them to a landfill.

Successful grasscycling requires proper mowing. Cut the grass when the leaf surface is dry, keep your mower blades sharp, and follow the one-third rule. With frequent mowing, you will have short clippings that will not cover the grass surface if left on the lawn and will quickly decompose.

There are times, however, when grasscycling is not appropriate. Prolonged wet weather, mower breakdowns, or other circumstances that reduce mowing frequency and thus lead to an excessive volume of clippings probably dictate that the grass clippings should be bagged. But do not throw those clippings away! Grass clippings make an excellent addition to a backyard compost pile. Clippings can also be used as mulch to provide weed control and prevent moisture loss in flower beds and around trees and shrubs. In some situations, however, you should not mulch with clippings: if the clippings are of an invasive species such as bermudagrass or if herbicides were recently applied to the lawn, the clippings can be harmful.

Table 1. Proper mowing heights and mower types for common California turfgrasses

Grass type	Climate adaptation	Mower height setting	Mow when grass reaches this height	Mower type
Bentgrass	cool-season	½–1 inch	¾–1½ inches	reel
Bermudagrass (common)	warm-season	1–1½ inches	1½–2¼ inches	reel or rotary
Bermudagrass (hybrid)	warm-season	½–1 inch	¾–1½ inches	reel
Buffalograss	warm-season	1–2 inches	1½–3 inches	rotary
Kentucky bluegrass	cool-season	1½–2½ inches	2¼–3¾ inches	reel or rotary
Kikuyugrass	warm-season	1–1½ inches	1½–2¼ inches	reel or rotary
Perennial ryegrass	cool-season	1½–2½ inches	2¼–3¾ inches	reel or rotary
Tall fescue	cool-season	1½–3 inches	2¼–4½ inches	reel or rotary
St. Augustinegrass	warm-season	1–2 inches	1½–3 inches	rotary
Zoysiagrass	warm-season	½–1½ inches	¾–2¼ inches	reel or rotary

MOWING EQUIPMENT

The two basic mower types are reel and rotary. A reel mower (Figure 1) shears grass with a scissors action and is better for fine-textured turfgrasses or where a low mowing height is desirable. A rotary mower (Figure 2) depends on impact cutting with a high-speed rotating blade, and is better suited to higher cutting heights and coarser-textured grasses. The type of mower recommended for best appearance of each grass species is given in Table 1.

The blades of a reel mower are powered either by a gear train connected to the wheels (hand-powered or push models) or by a gasoline engine. The blades of a rotary mower are driven by an electric motor or gasoline engine. If you use a gasoline-powered mower add fuel away from the grass, since an accidental gasoline spill will injure plants. If you use a non-battery electric mower, take care to avoid running over the cord.

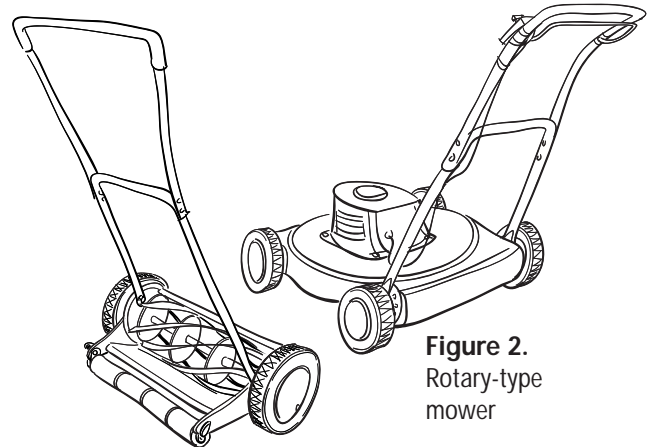

Figure 1. Reel-type mower

Figure 2.
Rotary-type
mower

You can adjust the mowing height on a reel or rotary mower. For a reel mower, simply place the mower on a flat surface and measure the distance from that surface to the bedknife. To adjust a rotary mower, look for index markers on the adjusters or consult your manual for instructions on height adjustment. Adjust to the desired height, but never adjust the mower height while the mower is running!

You can grasscycle with most mowers by removing the mower collection bag to allow clippings to drop on the lawn. However, if your mower does not have a safety flap covering the opening where the bag fits into the chute, purchase a retrofit kit before using the mower in this manner. Some lawnmower manufacturers have developed mulching or recycling mowers that cut grass blades into small pieces and force them into the soil. These mowers are effective for grasscycling and have become very popular. Several brands of recycling mowers are available in California.

MOWER SAFETY

- Study the instruction manual for manufacturer's recommendations on care and use of the mower.
- Never leave a running mower unattended.
- Keep people (especially children) and pets away from mowing operations.
- Before you mow, clear the lawn of all rocks, sticks, and other objects the mower can throw. Flying objects are hazardous.
- Keep hands and feet clear of moving parts.
- Work across slopes, not up and down.
- Don't pull a rotary mower backward unless absolutely necessary to maneuver the mower out of a tight spot.
- Stop the motor or engine or disengage the cutting blade when moving the mower across a driveway, walk, or unmowed area.

- Stop the engine or motor before you clean or adjust the mower.
- Remove the sparkplug wire (gasoline models) or disconnect the electrical supply (electric models) before working on the mower.
- Keep any gasoline in a safety can, and not in a glass jar or other improvised container.

ADDITIONAL MOWING TIPS

- Mow grass mixtures in a way that favors the predominant or most desirable grass.
- Do not mow wet grass: it sticks to mower blades and clogs the mower.
- Change the direction of mowing periodically to prevent a "washboard" effect.
- Sharpen lawnmower blades regularly. Dull mowers leave a ragged appearance from crushed or uncut grass blades, and damaged grass may be more susceptible to disease.
- Do not drastically or suddenly change the cutting height. If the grass has become too tall, re-establish the recommended height by mowing more frequently for a while and gradually lowering the mowing height of successive cuttings, following the one-third rule.
- Since mowing stresses the grass, do not mow a lawn under drought or other climatic stress conditions. Grass that is suffering from lack of water should be watered and allowed to dry before being mowed.
- Mow a shady lawn slightly higher and less frequently than is normally recommended for that grass species. Shade reduces photosynthesis, and slightly higher mowing heights allow more leaf surface that compensates for the lower light levels.

FOR MORE INFORMATION

You'll find detailed information on many aspects of turfgrass and landscape care in these UC ANR publications:

Pests of Landscape Trees & Shrubs, publication 3359

Turfgrass Irrigation Scheduling, publication 21492

Turfgrass Pests, publication 4053

Turfgrass Water Conservation, publication 21405

UC IPM Pest Management Guidelines for Turfgrass, publication 3365-T

Also of interest:

Grower's Weed Identification Handbook, publication 4030

Weeds of the West, publication 3350

To order these publications or to request of catalog of UC ANR publications, slide sets, and videos, contact

University of California

Division of Agriculture and Natural Resources

Communication Services

6701 San Pablo Avenue, 2nd Floor

Oakland, California 94608-1239

Telephone: 1-800-994-8849 or (510) 642-2431, FAX: (510) 643-5470

e-mail inquiries: danrcs@ucdavis.edu

Visit us on the World Wide Web: <http://danrcs.ucdavis.edu/>

An electronic version of this publication is available on the ANR Communication Services website at <http://danrcs.ucdavis.edu>.

Publication 8006

©1999 by the Regents of the University of California, Division of Agriculture and Natural Resources. All rights reserved.

The University of California prohibits discrimination against or harassment of any person employed by or seeking employment with the University on the basis of race, color, national origin, religion, sex, physical or mental disability, medical condition (cancer-related or genetic characteristics), ancestry, marital status, age, sexual orientation, citizenship, or status as a covered veteran (special disabled veteran, Vietnam-era veteran or any other veteran who served on active duty during a war or in a campaign or expedition for which a campaign badge has been authorized).

University Policy is intended to be consistent with the provisions of applicable State and Federal laws.

Inquiries regarding the University's nondiscrimination policies may be directed to the Affirmative Action/Staff Personnel Services Director, University of California, Agriculture and Natural Resources, 1111 Franklin, 6th Floor, Oakland, CA 94607-5200; (510) 987-0096.

pr-8/99-WJC/WS